



Page 1 of 9
Date: June 2011
Replaces: Form HD109E
Dated: Feb. 2009

BMC's IC-35-2F is a self-propelled industrial crane designed for in-plant lifting and material handling applications. It has the special features of low height, narrow width, short length, cargo deck, rear wheel steer, and front wheel drive. The basic unit consists of a chassis and hydraulic boom assembly. The chassis includes a frame, four hydraulic outriggers, engine, variable speed hydrostatic transmission, front driving and rear power steering axles. The boom assembly includes a hydraulic powered continuous rotation turret, 3-section telescopic boom, hydraulic boom elevating cylinder, hydraulic boom extension cylinders and hydraulic powered hoist. A Rated Capacity Limiter is also standard.

IC-35-2F:

3-section hydraulically extended boom with capacity of 8,000 pounds (3629 kg) at a 4-foot (1.2 m) load radius. Horizontal reach of 19 feet 2 inches (5.84 m) and vertical reach of 26 feet (7.92 m). Hoist is located on back of turret.

GENERAL:**Length:**

Chassis 9 feet 11 inches (3.02 m)
Overall 11 feet 11 inches (3.63 m)

Width:

5 feet 0 inches (1.52 m)

Height:

Deck 28 inches (71.12 cm)
Overall 6 feet 6 inches (1.98 m)

Wheelbase:

6 feet 0 inches (1.83 m)

Ground Clearance:

Chassis 7 inches (17.78 cm)
Minimum (Rear Axle) 5 inches (12.7 cm)

Angle of Approach:

26 degrees

Angle of Departure:

21 degrees

Turning Radius: (Min.)

11 feet 2 inches (3.40 m)

Aisle Width: 90 degree Turn (Min.)

8 feet 3 inches (2.52 m)

Travel Speed: (Max.)

10 mph (16 km/h)

Weight Distribution:

Front Axle: 3,780 pounds (1715 kg)
Rear Axle: 4,080 pounds (1850 kg)
Total 7,860 pounds (3565 kg)

Tire Footprint Area:

46 square inches (297 cm²), each

Outrigger Footprint Area:

48 square inches (310 cm²), each

Drawbar Pull:

2120 pounds (960 kg)

Gradeability:

30% (Calculated value based on GM 2.4L engine.)

Grade Limit:

20%

GENERAL:**Boom Movement:**

Rotation	Continuous
Elevation	70 degrees
Extension	12 feet (3.66 m)
Tail swing	3 feet 6 inches (1.07 m)

Boom Speeds:

Rotation	360 deg. in 39 sec. (1.5 rpm)
Elevation	17 seconds
Extension	32 seconds

Sheave Height:

Without Boom Extension	26 feet 0 inches (7.92 m)
With Boom Extension	33 feet 4 inches (10.16 m)

Horizontal Reach:

Without Boom Extension	19 feet 2 inches (5.84 m)
With Boom Extension	27 feet 2 inches (8.28 m)

Engine:**Standard:****GM 2.4L, Woodward EFI Dual Fuel, EPA Tier II Certified:**

Industrial gasoline engine complete with multi-port electronic fuel injection, dual fuel, and engine management system. Water-cooled, 4-cylinder, 147 CID (2.4 L), 3.44-inch (87.4 mm) bore, 3.94-inch (100 mm) stroke, 65 HP (48 kW) at governed speed of 2500 rpm. Maximum torque, 137 foot pounds (185 Nm) at 2300 rpm. 70-amp alternator, 13.5-gallon (51 L) gas tank, and 33 lb (15 kg) LPG tank. Includes high temperature, low oil pressure shutdown, engine management system, and a catalytic converter muffler.

Optional Engines and Accessories:**Kubota 2.4L, EPA Interim Tier 4 Certified:**

Kubota V2403-M-E3B diesel engine. Water-cooled, 4-cylinder, naturally aspirated, 148 CID (2.4 L), 3.43-inch (87 mm) bore, 4.03-inch (102 mm) stroke. 48.9 HP (36.5 kW) at governed speed of 2700 rpm. Maximum torque 118 ft-lbs (160 Nm) of torque at 1800 rpm. 12V, 40-amp alternator. Dry Weight: 406 pounds (184 kg)

No weight change from gasoline engine.

Spark Arrestor Muffler:

Spark arrestor muffler used in addition to standard muffler. Net Weight: 10 pounds (5 kg)

Engine Shutdown Kit:

Consists of Murphy switches that shut engine down if water temperature is excessive or oil pressure is too low. For diesel engine only.

Hydrostatic Transmission Pump:**Standard:**

Sauer-Danfoss piston type, 2.8 CID (45mL) per revolution, direct driven from engine crankshaft. Maximum flow 34 gpm (129 L/min) maximum pressure 4,000 PSI (275 bar). Electrohydraulic servo and electronic, automotive type controller.

Axles:**Standard:****Front Axle:**

Channel shaped structure houses torque hubs, brakes and hydraulic drive motors. Front axle oscillates a total of 1.5 inches (38 mm) to minimize wheel spin on uneven surfaces.

Rear Axle:

Fixed rigid to frame. Box beam crossmember and thrust bearing supported wheel hubs.

Steering:**Standard:**

Full-hydraulic steering unit controls 2.5 inch (63 mm) steering cylinder attached to rear axle. Limited steering if engine dies.

Brakes:**Standard:**

Primary braking from hydrostatic transmission. Foot-actuated disc brake attached to each torque hub for additional braking in some conditions. Parking brake switch locks brakes to hold crane when not being driven.

Tires:**Standard:**

7.50 x 10 pneumatic tires, 16 ply. Pressurized to 150 psi (1000 kPa) for crane rated loads.

Optional Tires:**Solid Rubber Tires:**

For applications where hazardous ground conditions exist. These tires do not change the overall height or ground clearance. Net Weight: 240 pounds (109 kg)

Solid Rubber Tires Non-Marking:

Same as solid rubber tires except non-marking. Net Weight: 240 pounds (109 kg)

Foam Filling of Tires:

Standard tires, foam filled to prevent flats. Net Weight: 312 pounds (142 kg)

Spare Tire & Wheel:

7.50 x 10 pneumatic tires, 16-ply. Front or rear axle must be specified. Net Weight: 80 pounds (37 kg)

Chassis:**Standard:****Cargo Deck:**

29 square foot (2.7 m²) area. A maximum of 6,000 pounds (2720 kg) may be carried on the deck when centered over or to the rear of the front axle. Nine stake pockets are provided in deck and nine 1.3 inch (34 mm) outside diameter pipe stakes.

Outriggers:

Four hydraulic outriggers with box beam construction. Independent controls for each. Hydraulic cylinders are equipped with direct connected holding valves. Pad dimensions are 6 inches (152 mm) by 8 inches (203 mm).

Lifting Rings:

Includes four lift rings, one at each corner of the chassis for attaching lifting sling cables.

Front Pulling Eye:

Heavy eye in front bumper provides for attachment of hook block so main winch line can be used for pulling loads at or near floor level.

Headlight and Taillight Grilles:

Consists of welded steel protective grilles for headlights and taillights. Easily removes or swings out of way for replacing bulbs.

Optional Chassis Accessories:**Auxiliary Winch:**

Optional worm gear winch mounted behind front bumper, with a single lever control at the operator's console. Hydraulic powered to provide bare-drum line pull of 3,000 pounds (1360kg) at 20 ft/min (6 m/min). Winch drum is 3.5 inch (89 mm) dia. by 6.2 inches (159 mm) long. The winch includes 80 feet (24.3 m) of 5/16 inch (7.94 mm) wire rope, hook, and four-way roller guide. Net Weight: 120 pounds (55 kg)

Pintle Hook:

T-60-A Holland pintle hook mounted on rear frame member. Rated for 10,000 pounds (44 kN) pull and 2000 pounds (8.9 kN) vertical load. Net Weight: 7 pounds (3 kg)

Optional Chassis Accessories: Con'd**Lifting Sling:**

Sling to attach to lifting rings. Net Weight: 20 pounds (9 kg)

Rear View Mirrors:

One right-hand and one left-hand mirror, 6" (152 mm) diameter, mounted on deck stakes. Pivot out of way when contacted by obstacle at side of deck. Net Weight: 12 pounds (6 kg)

Operator's Compartment:**Standard:**

Operator control station provides one-position access to all chassis and crane functions. Includes adjustable operator's seat and retracting seat belt.

Operator's Compartment Accessories:**All Weather Cab:**

Consists of rigid mounted canopy section and removable hinged door with safety glass. Rugged canopy structure with laminated glass front and top. Door is equipped with a keyed lock to protect operator's station. Cab door adds 4 inches (102 mm) to crane width on operator's side. Includes heater with two speed fan and 12V electric windshield wiper. Includes sliding window in the door and one fold out window in rear to provide flow-through ventilation. Defroster fan and dome light included. Net Weight: 180 pounds (82 kg)

Cab Heater:

Heater with two-speed fan, for units without All Weather Cab. Net Weight: 15 pounds (7 kg)

Operator Guard:

Tubular steel weldment with heavy expanded steel mesh top bolts over operator's compartment. Net Weight: 60 pounds (27 kg)

Operator Guard Cover:

Vinyl cover with windows to go over operator guard for inclement weather operations. Net Weight: 12 pounds (6 kg)

Floormat:

Ribbed vinyl mat with foam backing for operator comfort.

Electrical System:**Standard:****Electrical Group:**

12 Volt DC.

Battery:

Group 24 with 550 CCA rating.

Lighting Group:

Consists of two headlights, taillights, and 12V horn activated by button on instrument panel.

Instrument Group:

Located at operator's station and includes fuel gauge, ammeter, oil pressure, water temperature and hydraulic oil temperature gauges. Hourmeter records hours only during actual engine operation.

Outrigger Alarm System:

112 dB alarm with alternating two-tone sound is actuated by a switch when the "outrigger down" controls are operated.

Back-up Alarm:

Provides pulsating 97 dB sound from solid-state alarm when ignition is on and transmission is in reverse.

Optional Electrical Accessories:**Strobe Lights:**

Two yellow strobe lights mounted on turret for high visibility. Flash 60-120 times per minute. Draw 1/2 amps each. Includes operator-controlled switch.

Boom Work Lights:

Two work lights, one on side of boom to light boom tip, and one on side of turret to light ground under boom tip. Includes switch at operator's station. Net Weight: 10 pounds (5 kg)

Hydraulic System:**Standard:**

Tandem pump mounted to rear end of hydrostatic piston pump which is driven by the engine crankshaft. Delivers 6 gpm (23 L/min) at 2,600 psi (179 bar) for boom circuits and 17 gpm (64 L/min) at 2,250 psi (155 bar) for hoist circuit. System protected by relief valves and two 10-micron filters. Hydraulic reservoir with 14 gallons (53 L) capacity.

Boom Assembly:**Standard:**

Three section, high strength steel construction, equipped with bearing pads for efficient support and extension. Double-acting hydraulic cylinders extend boom sections. The primary extension cylinder and the double-acting boom elevation cylinder are equipped with direct connected holding valves. Boom angle indicator provided on both sides of boom.

Boom Hoist:**Standard:**

Turret mounted, planetary gear hoist is hydraulically powered to provide bare-drum line pull of 5,000 pounds (2268 kg) and a line speed of 86 ft/min (26 m/min). Hoist includes 85 feet (26 m) of 3/8 inch (9.5 mm) wire rope, downhaul weight, swivel hook, and sheave block for 2-part line. (Required for lifts over 4,000 pounds (1814 kg).) Sheave block weight is 60 pounds (27 kg). Downhaul weight is 40 pounds (18 kg).

Optional:**Extra-long Wire Rope:**

140 foot (42.6 m) long load line instead of standard 85 foot (26 m). Net Weight: 14 pounds (7 kg)

Boom Swing:**Standard:**

Heavy-duty ball bearing rotation gear with external teeth supports boom. Rotation is powered by hydraulic motor and worm gear drive. 360 degree continuous rotation.

Boom Attachments:**Standard:****Anti-Two-Block Device:**

Has electric solenoid dump valve which prevents damage to hoist rope and machine components from accidentally pulling load hook against boom tip. This valve will dump the **HOIST RAISE, TELESCOPE EXTEND, BOOM LOWER, and SWING LEFT/RIGHT** circuits. No other circuits are affected. These circuits are returned to normal operations by operating the **HOIST LOWER or TELESCOPE RETRACT** control. This system uses a trip arm to activate switch.

Rated Capacity Limiter:

Operator's aid that warns operator of impending overload with audible and visual signals. Has read-outs for load, boom angle, boom length and load radius. In the event of an overload, dumps the following boom functions: **HOIST RAISE, TELESCOPE EXTEND, BOOM LOWER, SWING LEFT, and SWING RIGHT**. These circuits are returned to normal by lowering load to a safe resting place with hoist or by retracting or raising boom to a shorter load radius. Key-operated, momentary override switch located under dashboard.

Optional Boom Attachments:

Boom Extension - 8 Foot (2.4 m):

Provides 8 feet (2.4 m) of additional length for lifting loads with load line. Boom extension may be stowed along side base boom section when not in use. Tip sheave, attaching brackets, and pins included. Deduct 100 pounds (45 kg) from Capacity Chart when boom extension is in stowed position. Includes switch and trip arm for Anti-Two-Block system. Net Weight: 130 pounds (59 kg)

Boom Extension - 8 Foot (2.4 m) Offset:

Same as standard boom extension except has three settings: 0 degrees (in-line), 15 degrees offset and 30 degrees offset. Net Weight: 150 pounds (68 kg)

Searcher Hook:

2000 pounds (907 kg) capacity. Swivel hook with spring latch hangs from support structure projecting outward from boom tip. Net Weight: 30 pounds (14 kg)

Specifications subject to change without notice.

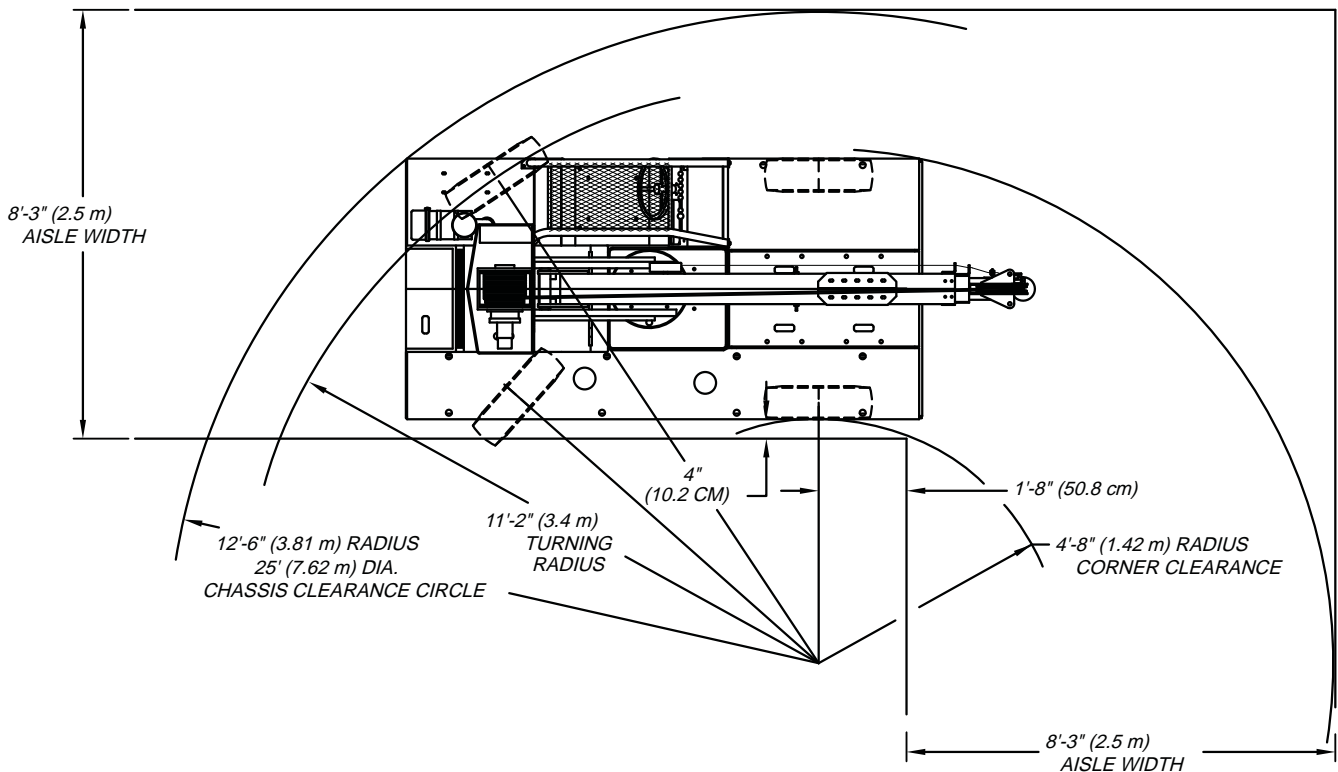

Should you require an option or special equipment not listed please consult your dealer salesperson or BMC®.

BRODERSON
Manufacturing Corp.
14741 West 106th Street
Lenexa, KS 66215 USA

Tel (913) 888-0606
Fax (913) 888-8431
www.bmccranes.com

Dimensions and values shown are
for reference purposes only.
Specifications subject to change.



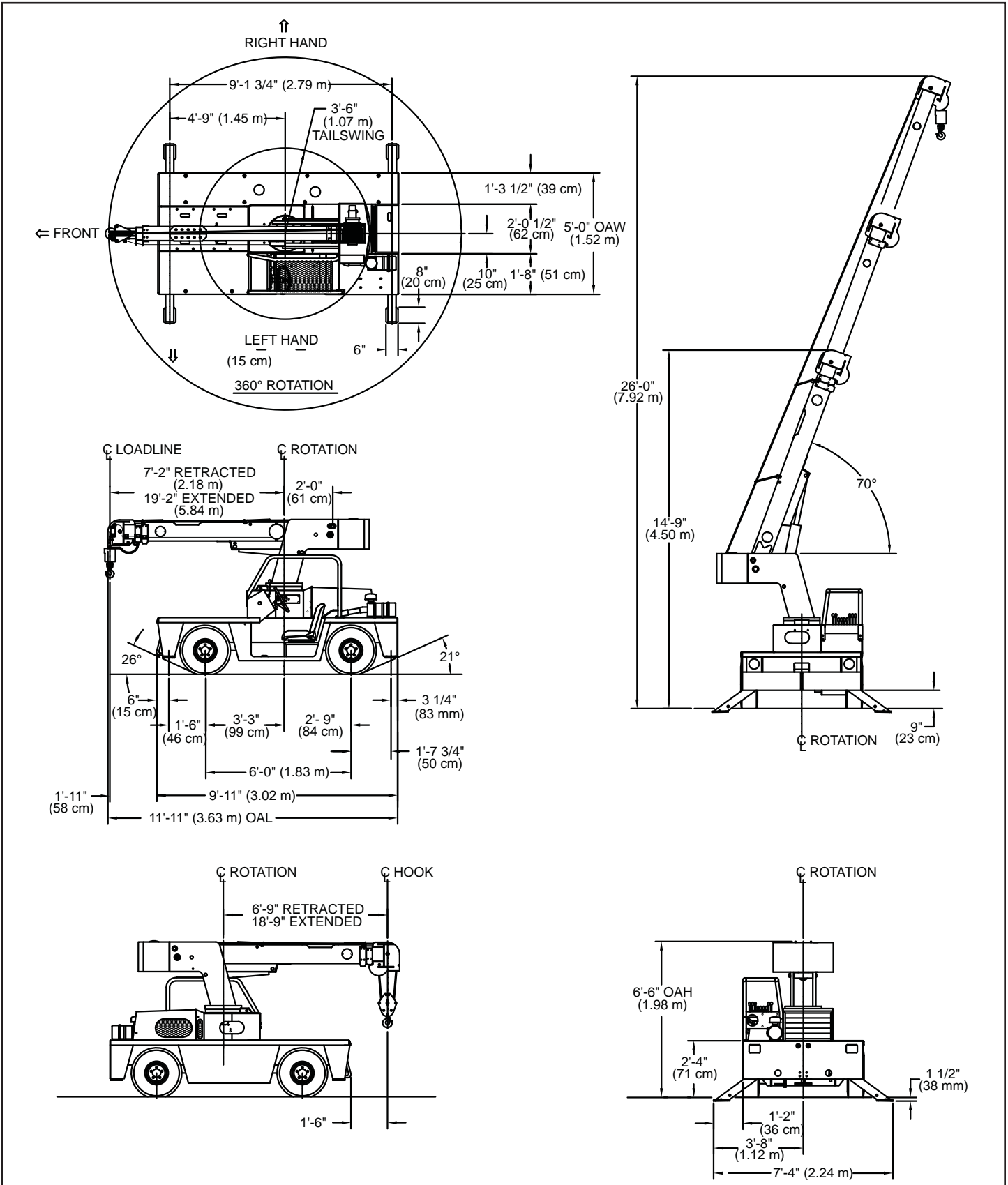

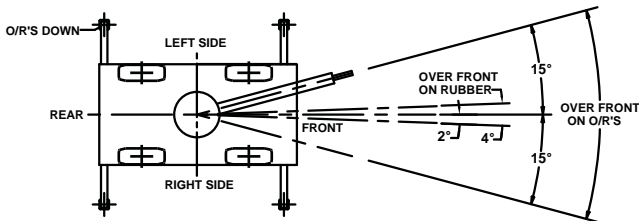
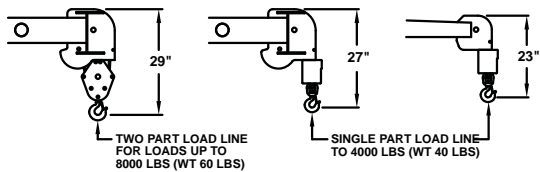
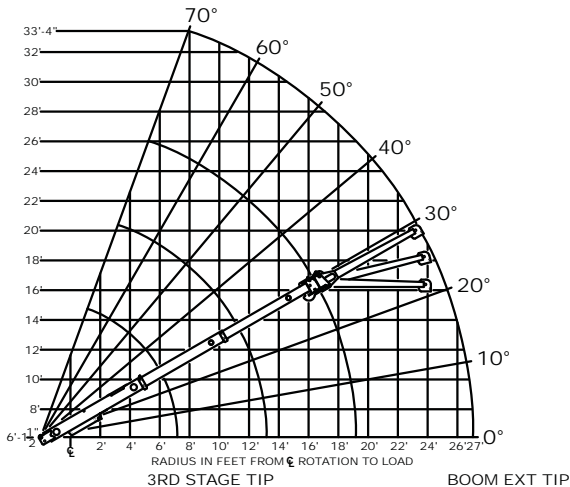

LOAD RADIUS IS THE HORIZONTAL DISTANCE FROM THE CENTER OF ROTATION OF THE UNLOADED CRANE TO THE VERTICAL LOAD LINE WITH THE LOAD APPLIED.

LOAD HOOKS, DOWNHAUL WEIGHTS, HOOK BLOCKS, AND OTHER LOAD HANDLING DEVICES EXCEPT HOIST ROPE SHALL BE CONSIDERED PART OF THE LOAD.

PICK AND CARRY WITH THE SHORTEST PRACTICAL BOOM, CENTERED OVER THE FRONT. OPERATE WITH THE BOOM AS LOW AS POSSIBLE, WITH THE LOAD CLOSE TO THE GROUND. PICK AND CARRY CAPACITIES ARE FOR SMOOTH, LEVEL PAVED SURFACE.

DECK LOAD 6000 LBS MAX, CENTERED BETWEEN WHEELS, WITH NO BOOM LOAD. DECK LOADS MUST BE CENTERED BEHIND THE FRONT AXLE. SPEED MUST BE LESS THAN 2 MPH. MAXIMUM TRAVEL 200 FT. IN 30 MINUTES.

CAPACITIES APPLY TO OPERATION ON FIRM LEVEL SURFACE

LOAD RADIUS FEET	MAIN BOOM OR EXTENSION CAPACITIES IN POUNDS							
	360° ROTATION		OVER FRONT					
	ON RUBBER	ON OUTRIGGERS	ON RUBBER	ON OUTRIGGERS				
4	5000	8000	6700	8000				
5	4000	6800	5800	6800				
6	2850	5850	5100	5850				
8	1800	4150	3500	4150				
10	1250	3200	2350	3400				
12	900	2350	1750	2850				
14	700	1850	1350	2450				
16	600	1500	1100	2150				
18	500	1250	950	1950				
19	450	1150	900	1850				
20	400	1100	850	1600				
22	300	900	700	1450				
24	250	800	600	1300				
26	200	700	500	1150				
27	150	650	450	1100				
BOOM EXTENSION - 8-FOOT BOOM EXTENSION - STRAIGHT OR OFFSET								
MAIN BOOM ANGLE								
ANGLE	0°	10°	20°	30°	40°	50°	60°	70°
+* 0°	1100	1200	1300	1450	1600	1850	2300	3500
* 15°	—	—	1100	1250	1350	1500	1700	2050
* 30°	—	—	—	1100	1200	1300	1450	1600

+ USE 0° FOR STRAIGHT BOOM EXTENSION.

* USE 0°, 15° OR 30° FOR OFFSET BOOM EXTENSION.

EXCEEDING CAPACITY RATINGS OR APPLYING SIDE LOADS TO THE BOOM OR BOOM EXTENSION IS MISUSE, IS HAZARDOUS, AND VOIDS WARRANTY.

CAUTION: BOOM EXTENSION LOADS MUST NOT EXCEED MAIN BOOM CAPACITY. BOOM EXTENSION DEDUCT: 100 LBS. WHEN STOWED ON BASE BOOM. DO NOT PICK & CARRY WITH LOADS ON BOOM EXTENSION. ENSURE ANTI-TWO-BLOCK SWITCH IS FUNCTIONAL AFTER DEPLOYING OR STOWING BOOM EXTENSION.

CAPACITIES ON OUTRIGGERS ARE 85% OF TIPPING LOADS. CAPACITIES ON RUBBER ARE 75% OF TIPPING LOADS. CAPACITIES BELOW BOLD LINE ARE LIMITED BY TIPPING. OTHER CAPACITIES ARE LIMITED BY STRUCTURAL OR HYDRAULIC CAPABILITIES.

BOOMS ON THIS UNIT ARE ALL STEEL AND HAVE NO LINE VOLTAGE RATING.

THE LOAD LINE ON THIS UNIT MUST BE 3/8 DIA. 6X36 EIP RRL IWRC WIRE ROPE (OR EQUIVALENT) WITH A MINIMUM BREAKING STRENGTH OF 15,100 LBS.

OPERATION:

1. READ AND UNDERSTAND OWNERS MANUAL BEFORE OPERATING THIS CRANE.
2. CHECK LEVEL OF ENGINE OIL AND HYDRAULIC OIL DAILY.
3. CHECK UNIT FOR VISIBLE DEFECTS DAILY.
4. EXTEND OUTRIGGERS FULLY IF POSSIBLE. IF NOT, USE "ON RUBBER" CHART.
5. AVOID QUICK STARTS AND STOPS WHEN OPERATING OR DRIVING CRANE.

TIRE PRESSURE: 145 PSI FOR 7.50 X 10-16PL.

MAXIMUM HYDRAULIC PRESSURE 2600 PSI.

IC-35-2F Metric Chart

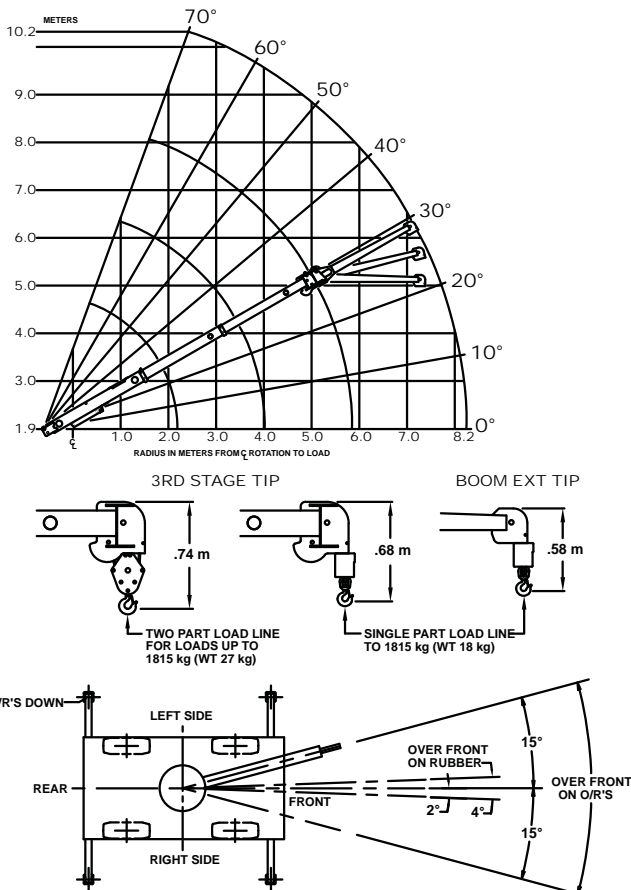

CAPACITIES APPLY TO OPERATION ON FIRM LEVEL SURFACE

LOAD RADIUS METERS	MAIN BOOM OR EXTENSION CAPACITIES IN KILOGRAMS								
	360° ROTATION		OVER FRONT						
	ON RUBBER	ON OUTRIGGERS	ON RUBBER	ON OUTRIGGERS					
1.2	2260	3620	3040	3630					
1.5	1850	3120	2650	3120					
2.0	1090	2420	2120	2420					
2.5	780	1830	1520	1830					
3.0	580	1480	1090	1560					
3.5	440	1160	850	1350					
4.0	350	920	680	1180					
4.5	300	770	560	1050					
5.0	260	650	480	950					
5.8	200	520	410	840					
6.0	190	500	390	750					
6.5	150	430	340	680					
7.0	120	380	290	620					
7.5	100	350	250	570					
8.2	70	290	200	500					
BOOM EXTENSION		2.44 m BOOM EXTENSION - STRAIGHT OR OFFSET							
ANGLE		MAIN BOOM ANGLE							
		0°	10°	20°	30°	40°	50°	60°	70°
+* 0°		500	540	590	660	720	840	1040	1590
* 15°		—	—	500	560	610	680	770	930
* 30°		—	—	—	500	540	590	660	720

+ USE 0° FOR STRAIGHT BOOM EXTENSION.

* USE 0°, 15° OR 30° FOR OFFSET BOOM EXTENSION.

EXCEEDING CAPACITY RATINGS OR APPLYING SIDE LOADS TO THE BOOM OR BOOM EXTENSION IS MISUSE, IS HAZARDOUS, AND VOIDS WARRANTY.

CAUTION: BOOM EXTENSION LOADS MUST NOT EXCEED MAIN BOOM CAPACITY. BOOM EXTENSION DEDUCT: 45 kg WHEN STOWED ON BASE BOOM. DO NOT PICK & CARRY WITH LOADS ON BOOM EXTENSION. ENSURE ANTI-TWO-BLOCK SWITCH IS FUNCTIONAL AFTER DEPLOYING OR STOWING BOOM EXTENSION.

CAPACITIES ON OUTRIGGERS ARE 85% OF TIPPING LOADS. CAPACITIES ON RUBBER ARE 75% OF TIPPING LOADS. CAPACITIES BELOW BOLD LINE ARE LIMITED BY TIPPING. OTHER CAPACITIES ARE LIMITED BY STRUCTURAL OR HYDRAULIC CAPABILITIES.

BOOMS ON THIS UNIT ARE ALL STEEL AND HAVE NO LINE VOLTAGE RATING.

THE LOAD LINE ON THIS UNIT MUST BE 10 mm DIA. 6X36 EIP RRL IWRC WIRE ROPE (OR EQUIVALENT) WITH A MINIMUM BREAKING STRENGTH OF 67 kN.

OPERATION:

1. READ AND UNDERSTAND OWNERS MANUAL BEFORE OPERATING THIS CRANE.
2. CHECK LEVEL OF ENGINE OIL AND HYDRAULIC OIL DAILY.
3. CHECK UNIT FOR VISIBLE DEFECTS DAILY.
4. EXTEND OUTRIGGERS FULLY IF POSSIBLE. IF NOT, USE "ON RUBBER" CHART.
5. AVOID QUICK STARTS AND STOPS WHEN OPERATING OR DRIVING CRANE.

TIRE PRESSURE: 1000 kPa FOR 7.50 X 10-16PL

MAXIMUM HYDRAULIC PRESSURE 180 bar

LOAD RADIUS IS THE HORIZONTAL DISTANCE FROM THE CENTER OF ROTATION OF THE UNLOADED CRANE TO THE VERTICAL LOAD LINE WITH THE LOAD APPLIED.

LOAD HOOKS, DOWNHAUL WEIGHTS, HOOK BLOCKS, AND OTHER LOAD HANDLING DEVICES EXCEPT HOIST ROPE SHALL BE CONSIDERED PART OF THE LOAD.

PICK AND CARRY WITH THE SHORTEST PRACTICAL BOOM, CENTERED OVER THE FRONT. OPERATE WITH THE BOOM AS LOW AS POSSIBLE, WITH THE LOAD CLOSE TO THE GROUND. PICK AND CARRY CAPACITIES ARE FOR SMOOTH, LEVEL PAVED SURFACE.

DECK LOAD 2720 kg MAX, CENTERED BETWEEN WHEELS, WITH NO BOOM LOAD. DECK LOADS MUST BE CENTERED BEHIND THE FRONT AXLE. SPEED MUST BE LESS THAN 3 km/h. MAXIMUM TRAVEL 60 m IN 30 MINUTES.